

AN11062

Broadband DVB-T UHF power amplifier with the BLF888A

Rev. 1 — 30 May 2011

Application note

Document information

Info	Content
Keywords	BLF888A, DVB-T, UHF broadcast
Abstract	This application note describes the design and performance of a DVB-T UHF power amplifier using the BLF888A.



Revision history

Rev	Date	Description
v.1	20110530	initial version

Contact information

For more information, please visit: <http://www.nxp.com>

For sales office addresses, please send an email to: salesaddresses@nxp.com

1. Introduction

For the past few years, new product design in the broadcast industry has been dominated by emerging digital modulation standards. A specific example is broadcast television, where many new transmitter systems are currently being set up as part of the conversion to digital terrestrial television.

The BLF888A is a UHF LDMOS power transistor intended for the broadcast transmitter market. The BLF888A can deliver 110 W DVB-T average power over the full UHF band from 470 MHz to 860 MHz at a CCDF of 8 dB (0.01 % probability). Higher average DVB-T power (120 W average) is possible depending on required linearity and predistorter capabilities. The transistor is also capable of handling analog TV (ATV) signals. The average power delivered will be dependent on cooling conditions.

Today, UHF transmitter design focuses on increasing efficiency and output power, while reducing size. To achieve these goals, the next generation of UHF transistors must deliver greater power levels, increased efficiency and higher gain, and the size of application boards needs to be reduced. The BLF888A meets these requirements. The BLF888A has been optimized for extreme low thermal resistance ($R_{th(j-c)} = 0.15$ K/W) and improved ruggedness (> 40 : 1 at 860 MHz).

This report describes a broadband application incorporating the BLF888A, built on a small form factor board with a total size of 105 mm × 50 mm.

2. Circuit description

The BLF888A broadband application circuit is shown in [Figure 1](#). It is a Class AB common source amplifier. Circuit dimensions are 105 mm × 50 mm (including the transistor). If the connectors are excluded, the dimensions are 95 mm × 50 mm. The PCB material is Taconic RF35 ($\epsilon_r = 3.5$) with a thickness of 0.76 mm.

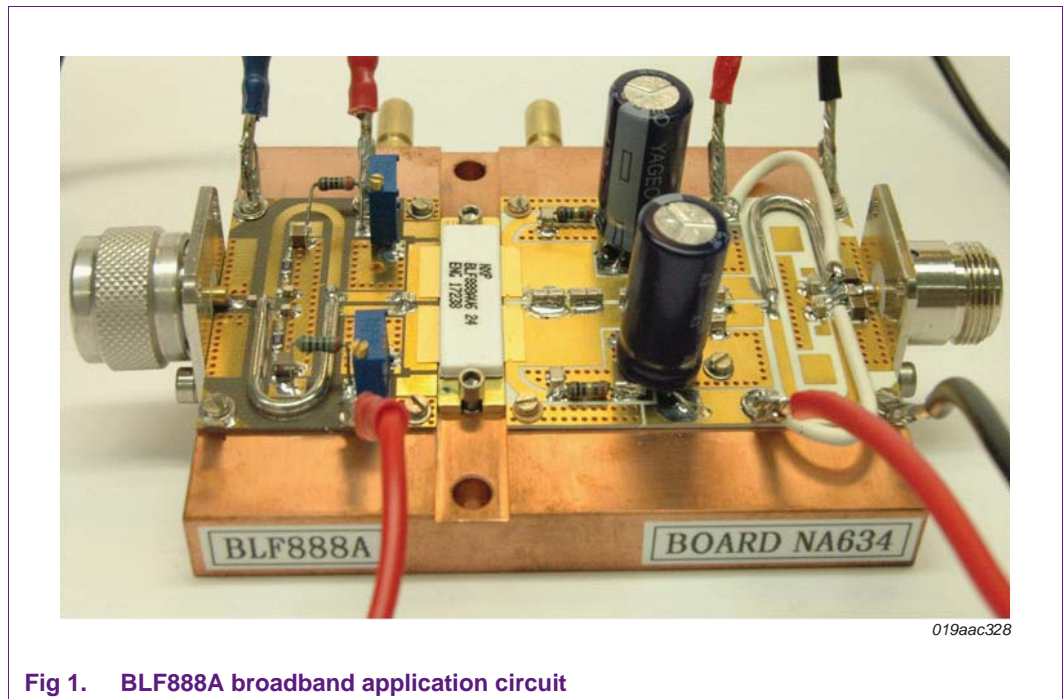

Fig 1. BLF888A broadband application circuit

A schematic diagram of the application design is shown in [Figure 2](#). The output consists of two microstrip lines per side, L1 and L2, and a balun B1 (25 Ω). C1 to C9 are used to match the transistor impedance to the input impedance of the balun (25 Ω). The balun converts the 25 Ω differential impedance to a 50 Ω asymmetrical impedance at the output. The length of the balun is approximately $\lambda/8$ at the UHF middle frequency. Microstrip line L3 is connected to the differential input of the balun to improve symmetry of the impedance to ground.

L5 in combination with C17 and C18 improves matching at the lower UHF frequencies. C11 and C12 influence the common mode impedance and improve the harmonic behavior. R1 and R2 were added for low frequency damping.

The input also consists of two microstrip lines, L30 and L31, and a balun B2 (25 Ω). C34 and C35 are RF decoupling capacitors for the balun. The transistor gate supply is connected via an RC network consisting of resistors R3 to R6, along with C36 and C37. This RC network performs a damping function that helps improve stability. Microstrip line L32 performs the same function at the input as microstrip line L3 at the output.

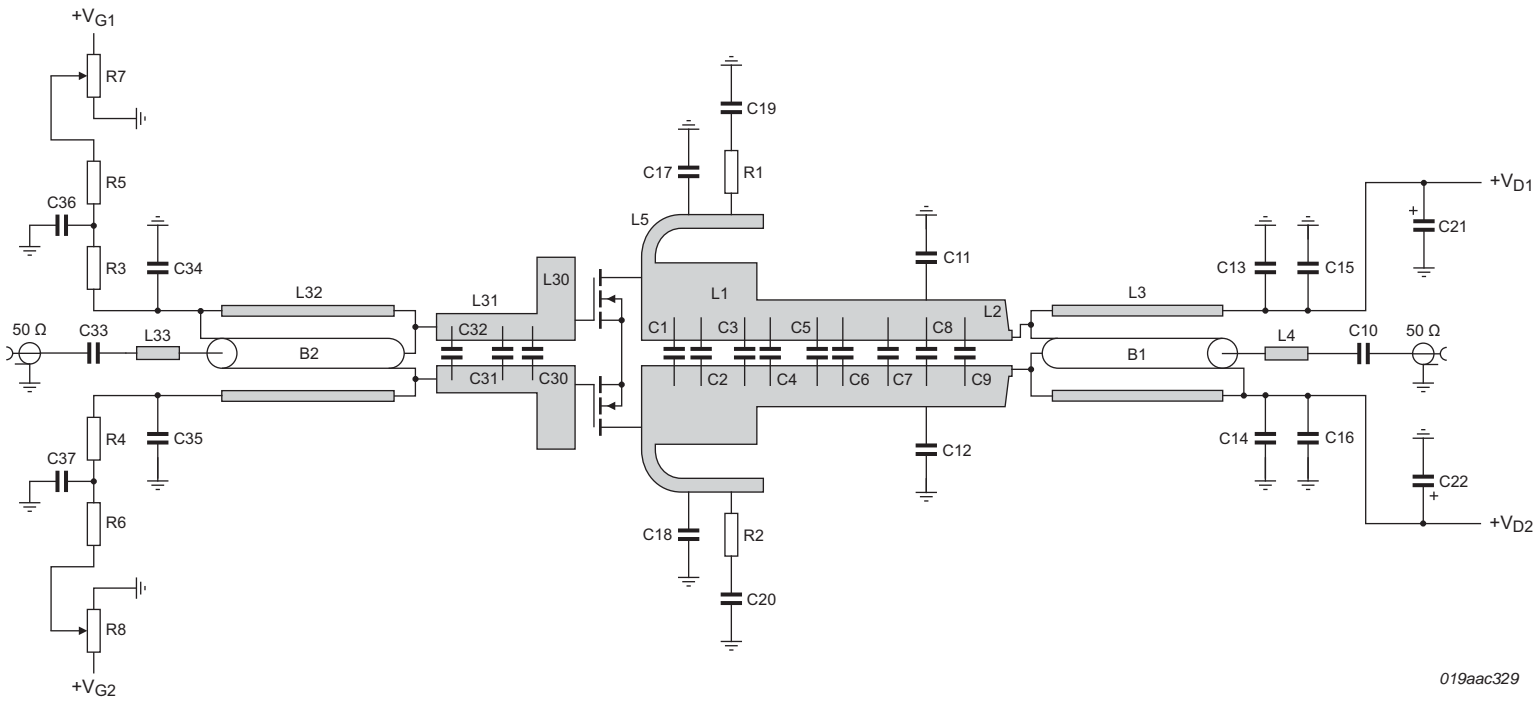

Fig 2. Class-AB common-source broadband amplifier

3. Design and Simulation

3.1 BLF888A impedance and simulation data

The impedance data detailed in [Figure 3](#) and [Figure 4](#) was used as a starting point in the development of the broadband circuit. This data is simulated from the equivalent circuit of the transistor. By using the equivalent circuit, impedances can be simulated from the internal drain current source and gate capacitance.

The push-pull and common mode simulation results for the broadband application circuit are shown in [Figure 6](#) and [Figure 7](#) respectively. The (common mode) low impedance in the second harmonic band (940 MHz to 1720 MHz) is of particular significance in the simulation. The resonance peaks in common mode can be shifted via capacitors C11 and C12 (see [Figure 2](#)). A high second harmonic impedance will result in significant power and efficiency losses.

3.1.1 Impedance data

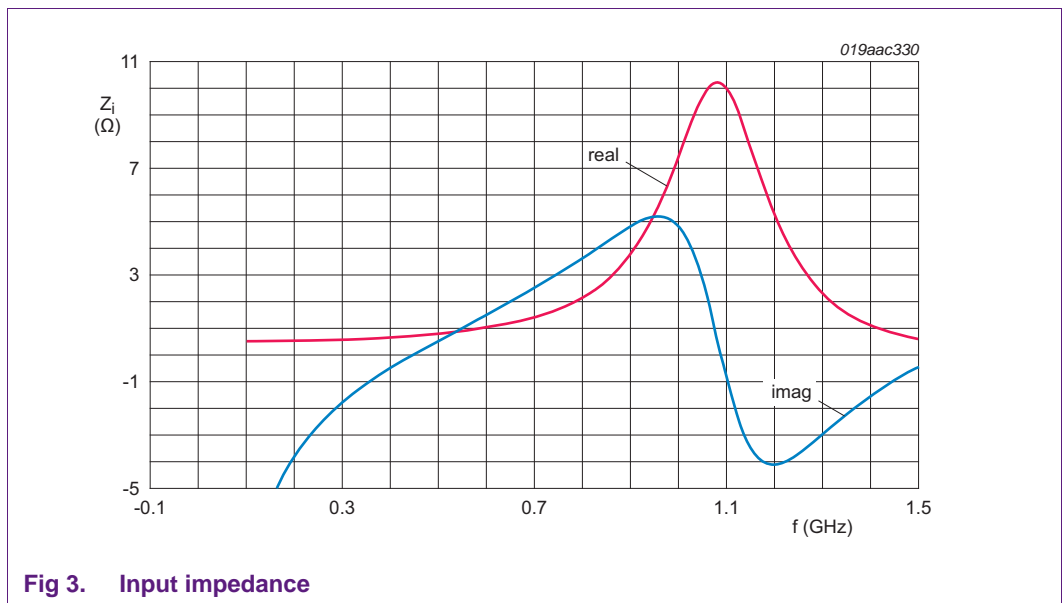

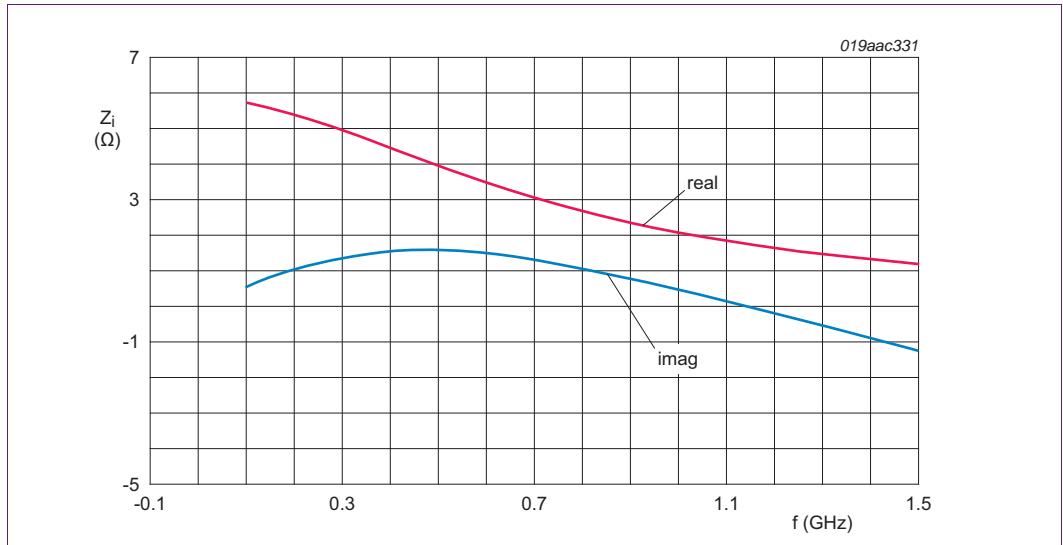

Fig 4. Output impedance; $P_O = 110$ W DVB-T (total device)

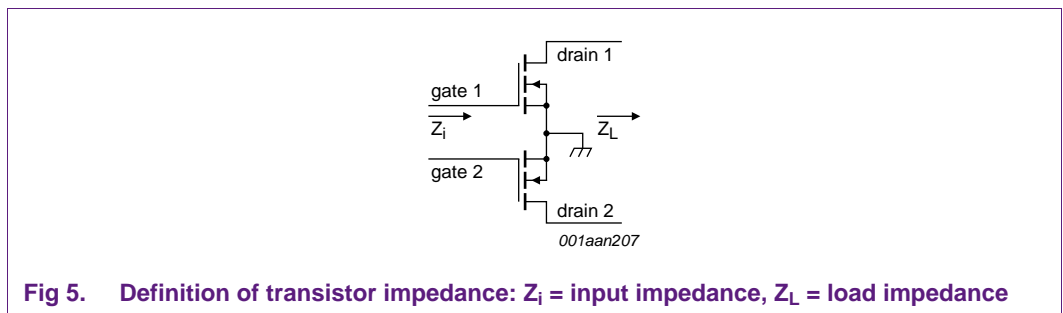
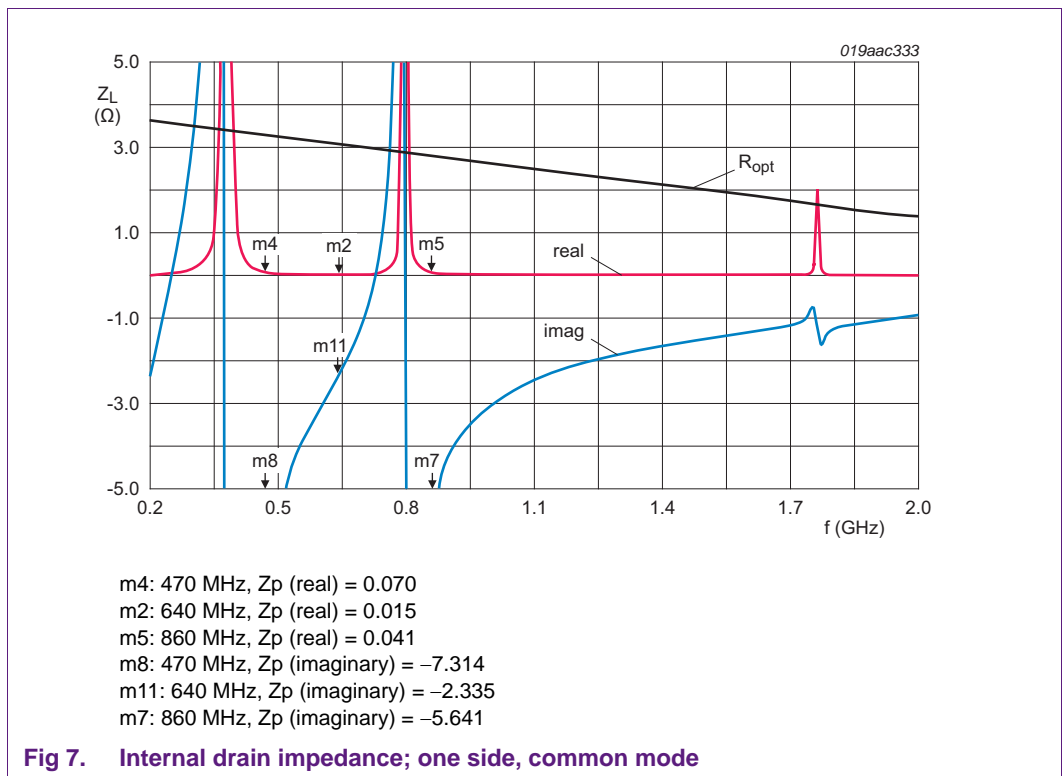
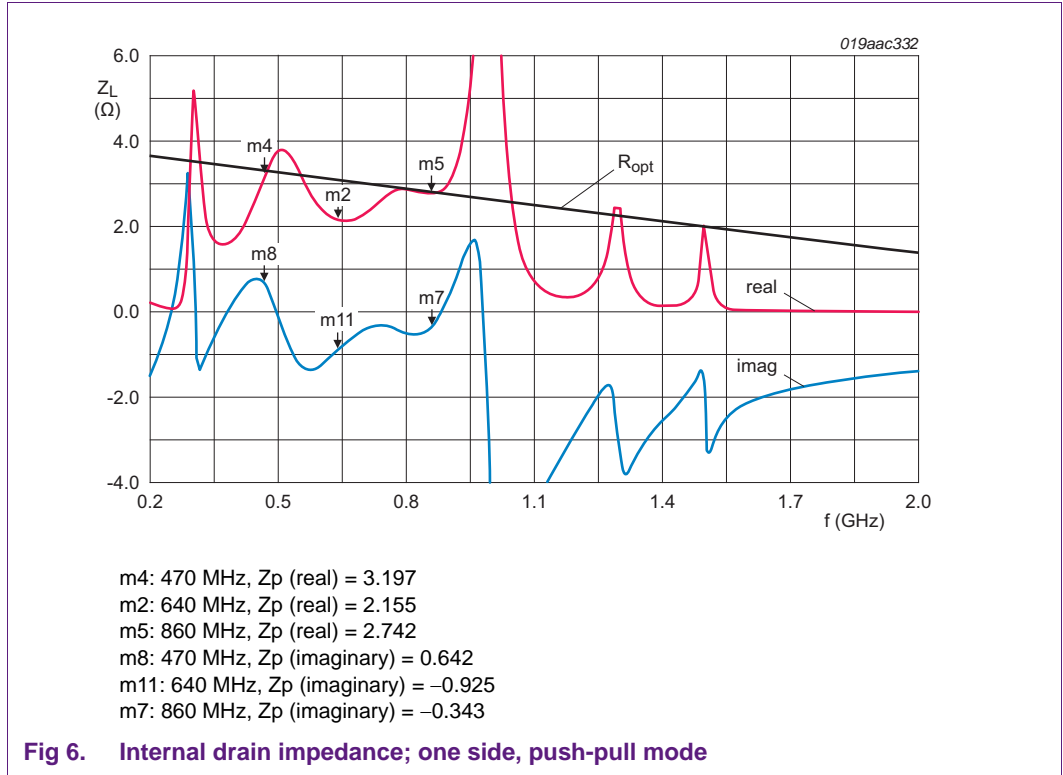

Fig 5. Definition of transistor impedance: Z_i = input impedance, Z_L = load impedance

3.1.2 Simulation data



3.2 Bias and decoupling circuit

The RF amplifier is sensitive to oscillations during mismatch. Therefore special care was taken to ensure adequate low frequency clamping at both the input and at the output. Two clamping resistors, R1 and R2, were added at the output for this purpose. Also, the supply is connected to the balun at the output. At the input, clamping is achieved via the RC network connected to the balun.

3.3 Thermal considerations

The circuit is designed to deliver 110 W DVB-T average power. The transistor can also handle CW, 2-tone and analog TV signals. However the power dissipation and heat generated by the transistor and the circuit can be excessively high, especially with CW and analog TV signals. The maximum junction temperature of the transistor is 200 °C. The electromagnetic (see [Ref. 1](#)) and lifetime (20 years minimum) restrictions must also be respected.

In this circuit, power dissipation is limited by the matching capacitors C1 and C2, and the balun ($P_{\max} = 150$ W (average)). For short-term testing, the circuit can handle CW power levels up to 450 W.

4. Test results

4.1 Large signal measurements

The test circuit was evaluated for DVB-T (110 W to 130 W average), 2-tone (250 W average) and pulsed CW. Besides the standard tests, special measurements were added with V_{DS} variation (46 V to 50 V) and water temperature variation (20 °C to 60 °C)

The demo circuit has a soldered transistor. This gives the best RF performance. A comparison is shown between a soldered and a clamped transistor.

The measurement results are shown in [Figure 8](#) to [Figure 13](#). All measurements were taken at $V_{DD} = 50$ V, $I_{Dq} = 1.3$ A (except for the V_{DS} variation) and $T_{\text{water}} = 20$ °C (except for the $T_{\text{hs}}/T_{\text{water}}$ variation).

4.1.1 DVB-T

The target for the broadband circuit was to achieve average output power ($P_{L(AV)}$) of 110 W with a Peak-to-Average power Ratio (PAR) of 8 dB at a CCDF of 0.01 %. This target was met over the entire frequency range from 470 MHz to 860 MHz. Lead contact and capacitor positioning were extremely important in ensuring the target was met at the critical higher UHF frequencies (above 800 MHz). Shoulder distance is less than -30 dBc and gain is greater than 20 dB over the entire frequency band.

Drain efficiency (η_D) is greater than 28 % and is typically 30 % (at 110 W). Efficiency at the less responsive frequencies can be improved by lowering the supply voltage (the margin of the PAR at the less responsive frequencies in terms of η_D is wide enough to allow the supply voltage to be lowered).

The influence of the cooling conditions (liquid cooled) can be seen in [Figure 11](#). The influence on CCDF / η_D is marginal in the measured range of T_{water} (20 °C to 60 °C). Gain will change by max. 1 dB.

Mounting has a significant effect on RF performance. This is shown in [Figure 12](#). Obviously best figures are achieved with a soldered transistor (CCDF / η_D). The comparison (soldered / clamped) was made with 2 different compounds: graphite (Fischer thermal transfer compound WLPG) and Austerlitz WPS-2 (without silicone). The graphite compound is electrically conducting and gives slightly better thermal / RF results.

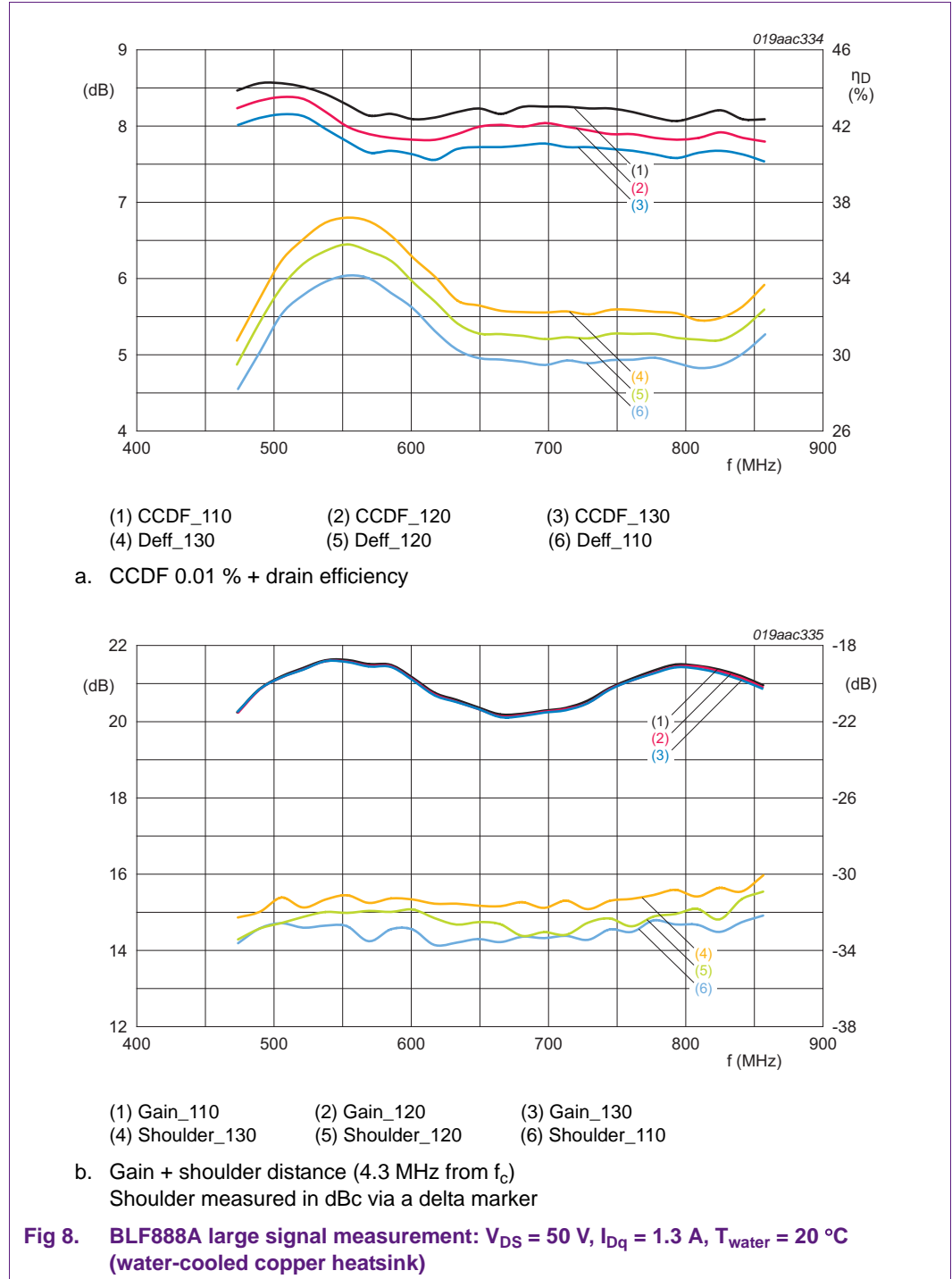

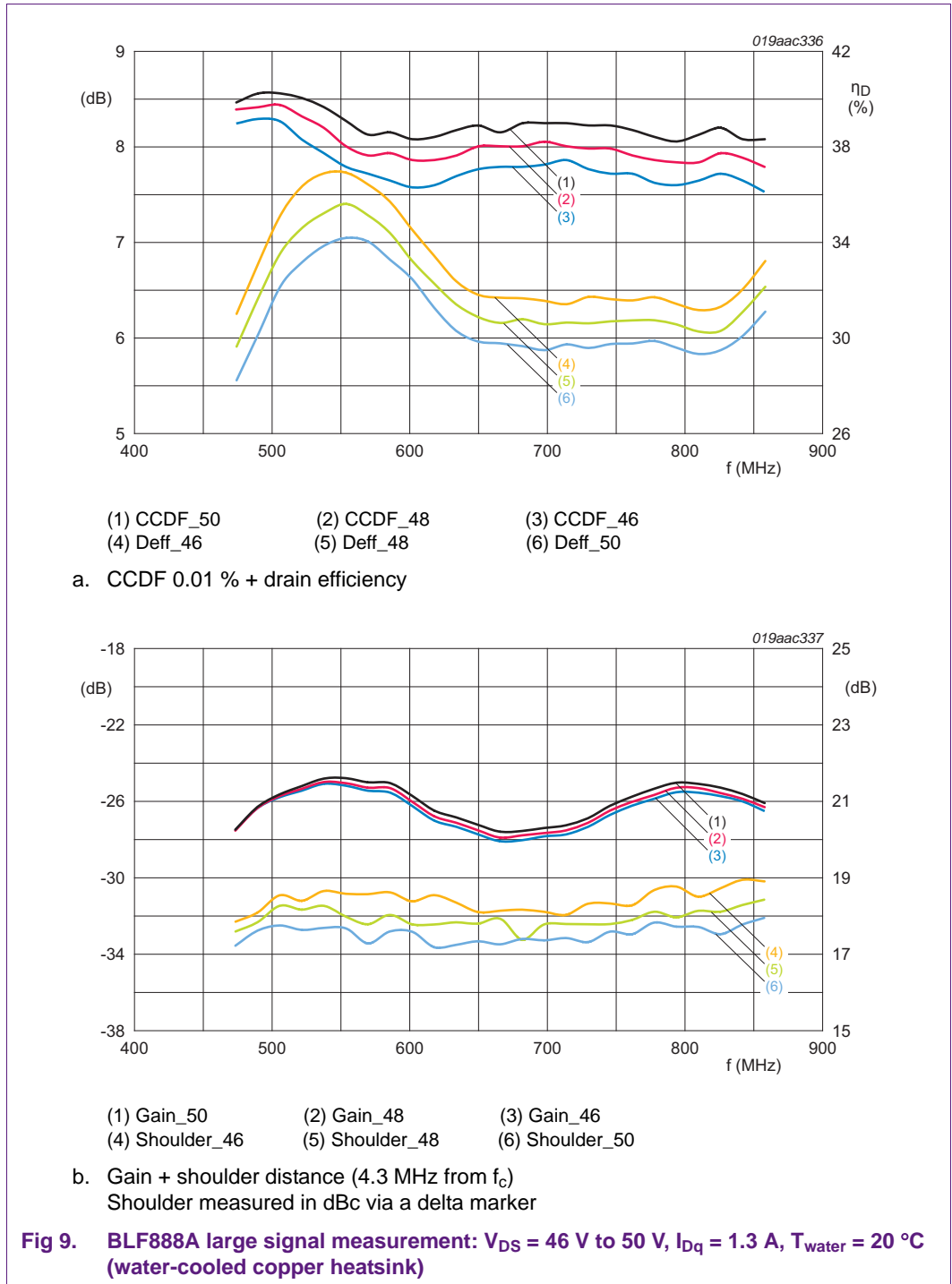

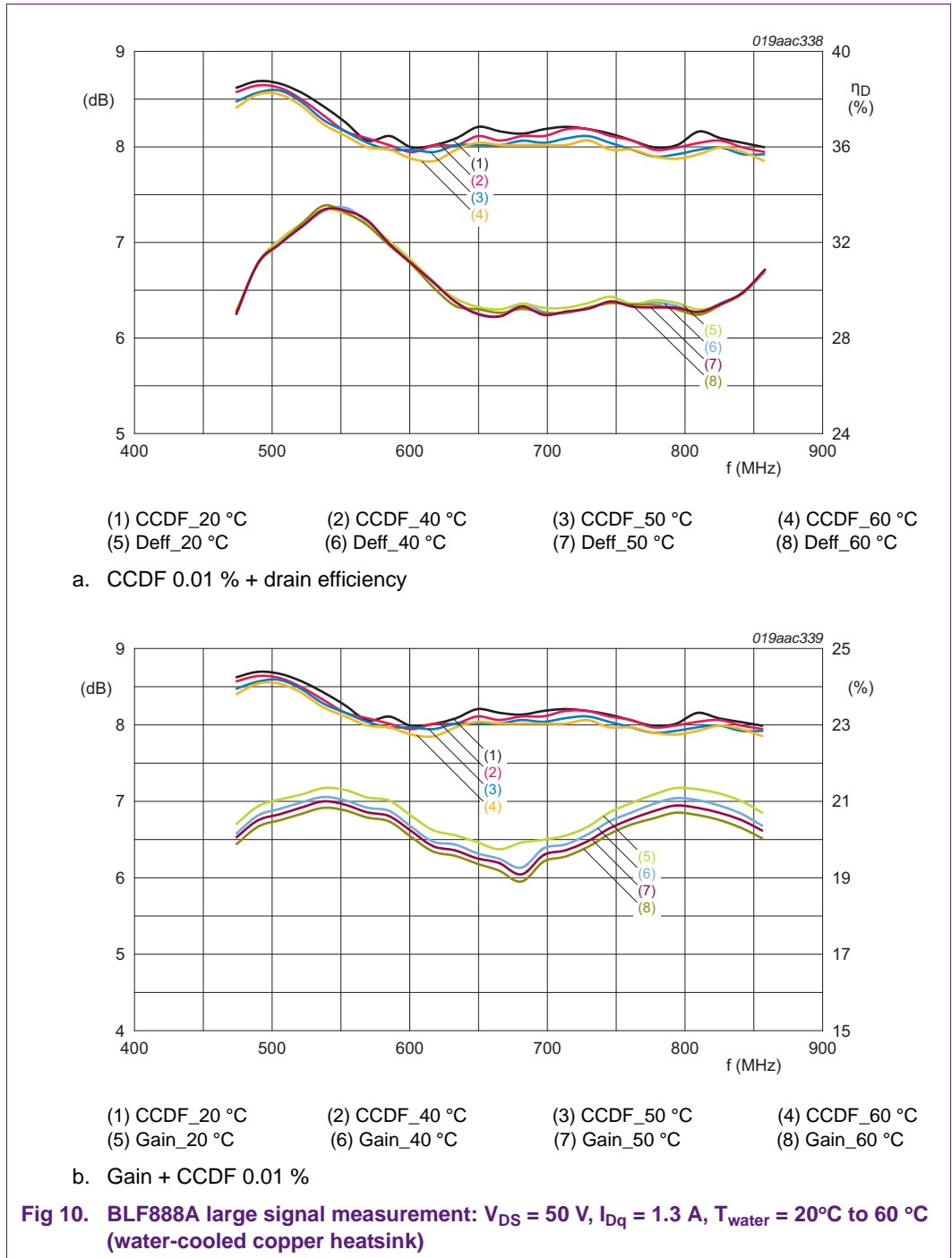



4.1.2 2-tone

Measurements were taken at $P_{L(AV)} = 250\text{ W}$ (average). IMD3 levels are well below -30 dBc over the entire UHF frequency range. At these power levels, drain efficiency $> 40\%$ and gain $> 20\text{ dB}$.

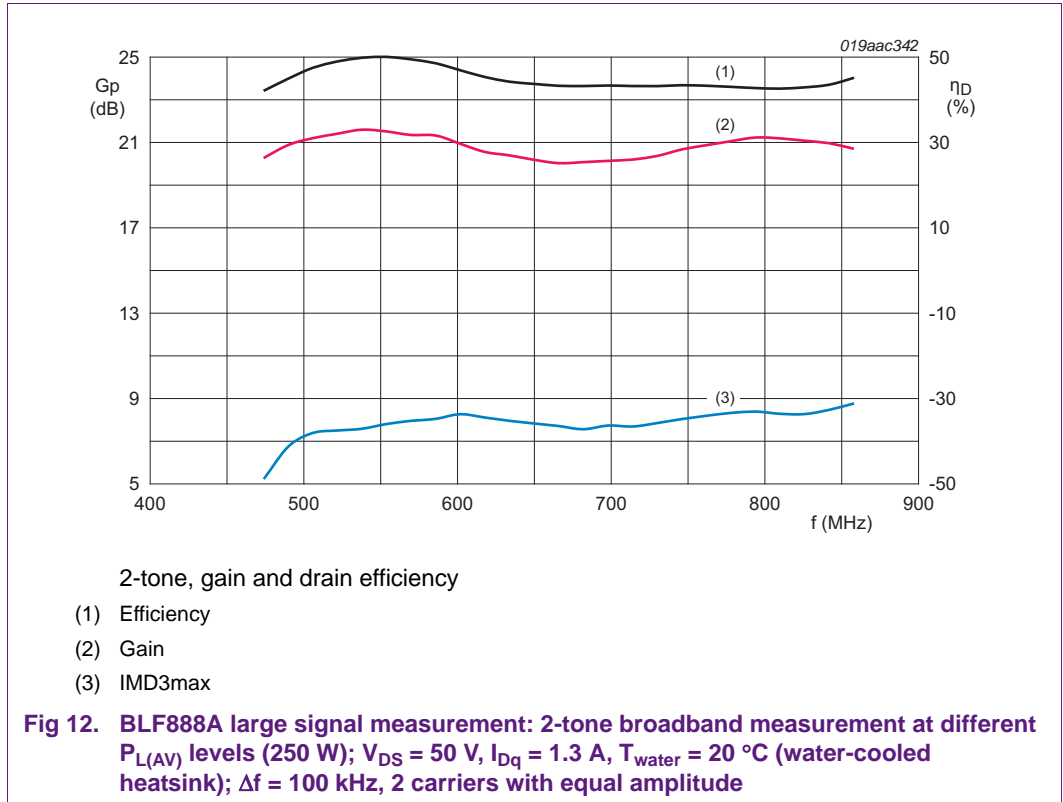

4.1.3 Pulsed

Pulsed measurement results between 470 MHz and 860 MHz (duty cycle = 10 %, $t_p = 100\text{ }\mu\text{s}$) are shown in [Figure 13](#) (response at 650 MHz and 850 MHz). This provides a clear illustration of the peak power capability of transistor plus circuit. The lowest peak power level ($\approx 600\text{ W}$) occurs at 860 MHz (due to the longer pulse duration, this is lower than the peak power with DVB-T).

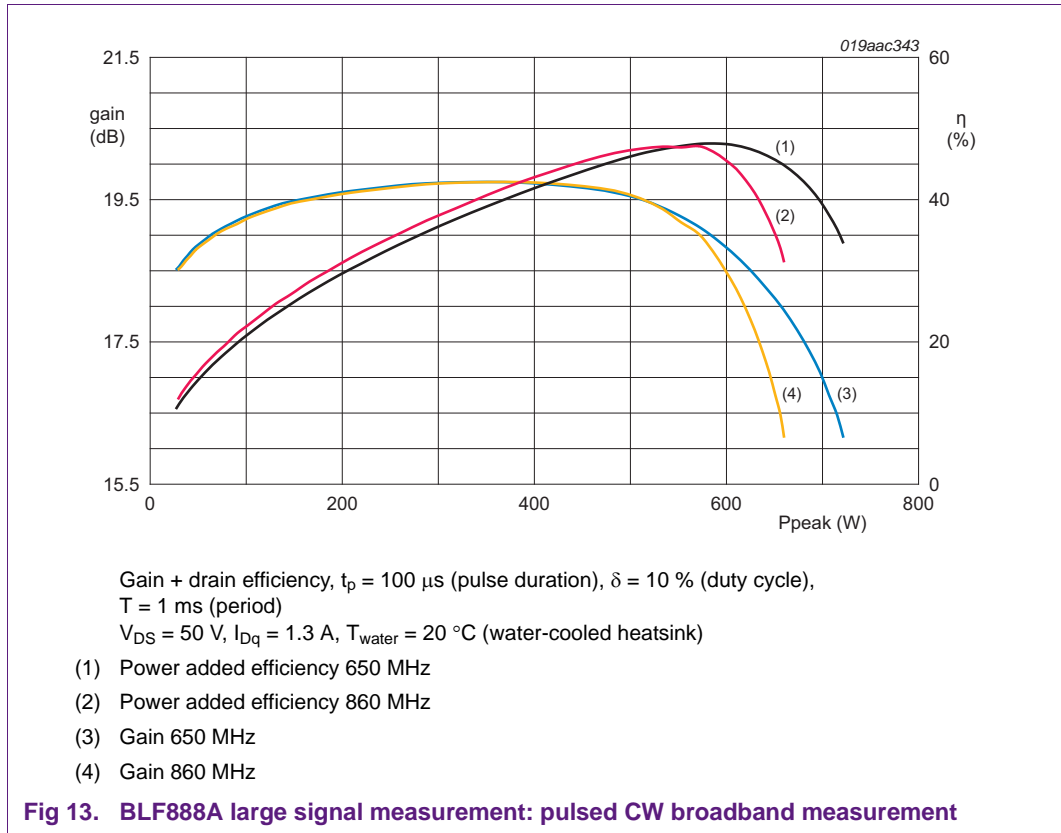

5. Conclusion

The BLF888A broadband application circuit presented in this report fulfils the following requirements:

- $P_{L(AV)}$ DVB-T > 110 W
- Efficiency > 28 % (typ. 30 %)
- Shoulder distance < -30 dBc (typ. -33 dBc)
- Gain > 20 dB (typ. 21 dB)

The circuit was designed for 110 W average DVB-T. The BLF888A is capable of delivering higher average power levels (e.g. in an ATV application). In such applications, special care must be taken to ensure adequate cooling is provided for the transistor and the circuit will need some redesign to handle the higher average power levels (e.g. the balun size).

The transistor has an extremely low R_{th} (0.15 K/W) which guarantees low junction temperatures and high reliability. It also enables the use of analog modulated TV signals.

Critical aspects of this broadband design include the harmonic loading (especially the 2nd harmonic of frequencies below 500 MHz), lead contact (an 'air gap' will shift the impedance level significantly) and low frequency stability (several damping resistors were added).

The transistor has an excellent ruggedness, with measured VSWR at 860 MHz > 40:1. Other frequencies show at least a VSWR >10:1.

6. Appendix A: PCB layout and Bill of Materials

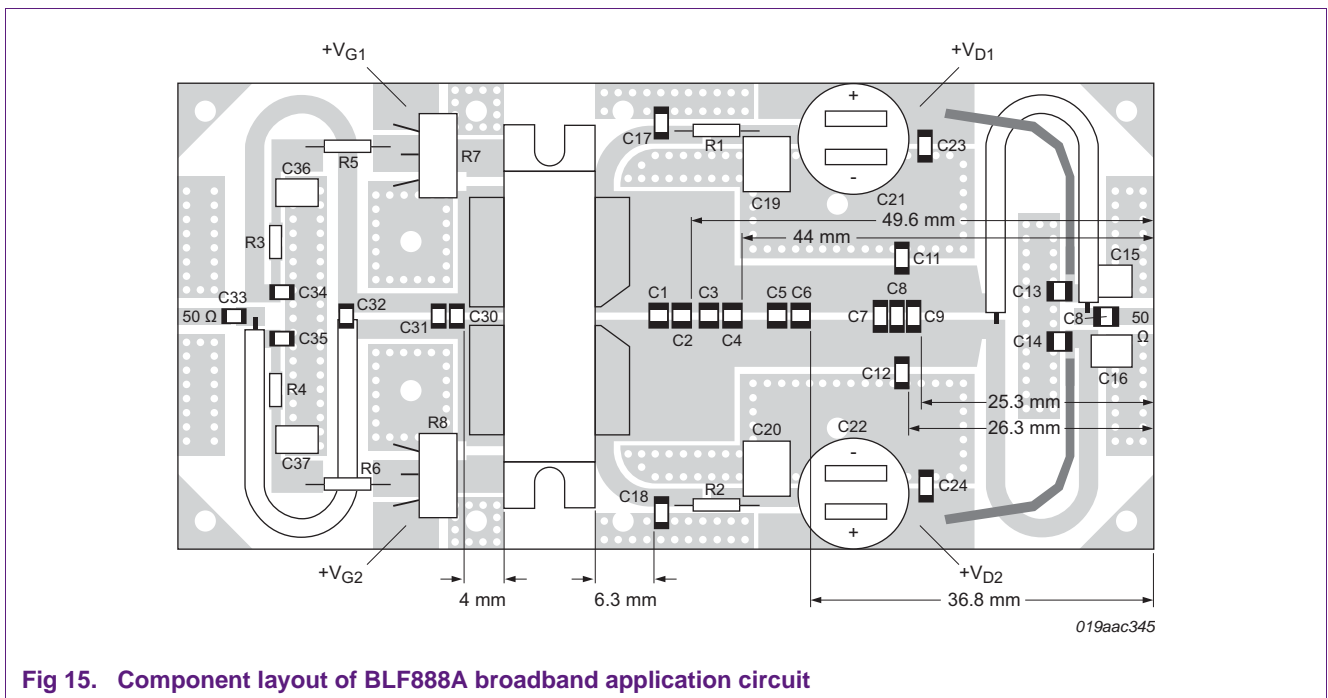
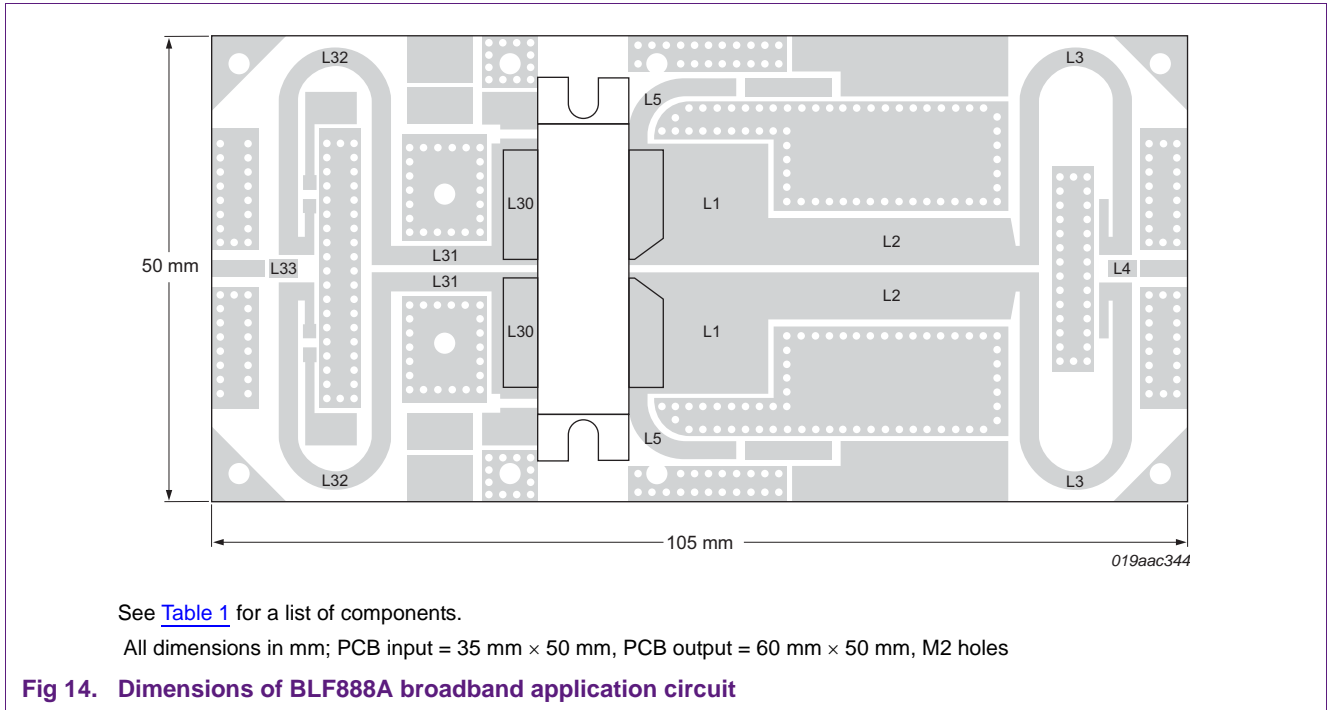

Table 1. Parts list for BLF888A broadband application circuit

Component	Value	Type	Comment
Output			
C1	12 pF	ATC180R	
C2, C3, C4, C5, C6	8.2 pF	ATC180R	
C7	6.8 pF	ATC100B	
C8	2.7 pF	ATC180R	
C9	2.2 pF	ATC100B	
C10, C13, C14	100 pF	ATC180R	
C11, C12	10 pF	ATC100B	
C17, C18, C23, C24	100 pF	ATC180B	
C15, C16	4.7 μ F	TDK C4532X7R1E475MT020U	50 V
C19, C20	10 μ F	TDK C570X7R1H106KT000N	50 V
C21, C22	470 μ F	electrolytic capacitor	63 V
R1, R2	10 Ω		
L1	15 mm \times 13 mm	microstrip line	length \times width
L2	26 mm \times 5 mm	microstrip line	length \times width
L3	49.5 mm \times 2 mm	microstrip line	length \times width
L4	3.5 mm \times 1.7 mm	microstrip line	length \times width
L5	9.5 mm \times 2 mm	microstrip line	length \times width
balun B1	semi-rigid coax $Z_0 = 25 \Omega$; 49.5 mm	UT-090C-25 (EZ 90-25)	
PCB		Taconic RF35, $\epsilon_r = 3.5$ height = 0.76 mm; 50 mm \times 60 mm Cu plating 35 μ m	
Input			
C30	10 pF	ATC100A	
C31	9.1 pF	ATC100A	
C32	3.9 pF	ATC100A	
C33, C34, C35	100 pF	ATC100A	
C36, C37	4.7 μ F	TDK C4532X7R1E475MT020U	
R3, R4	5.6 Ω		
R5, R6	100 Ω		
R7, R8	1 k Ω	potentiometer	
L30	13 mm \times 5 mm	microstrip line	length \times width
L31	11 mm \times 2 mm	microstrip line	length \times width
L32	49.5 mm \times 2 mm	microstrip line	length \times width
L33	3 mm \times 2 mm	microstrip line	length \times width
balun B2	semi-rigid coax $Z_0 = 25 \Omega$; 49.5 mm	UT-090C-25 (EZ 90-25)	

Table 1. Parts list for BLF888A broadband application circuit ...continued

Component	Value	Type	Comment
PCB		Taconic RF35, $\epsilon_r = 3.5$ h = 0.76 mm; 35 mm × 50 mm Cu plating 35 μm	

7. Abbreviations

Table 2. Abbreviations

Acronym	Description
CCDF	Complementary Cumulative Distribution Function
DVB	Digital Video Broadcast
DVB-T	Digital Video Broadcast - Terrestrial
UHF	Ultra High Frequency
CW	Continuous Wave
IMD3	Third-Order Intermodulation Distortion
PEP	Peak Envelope Power

8. References

- [1] BLF888A data sheet

9. Legal information

9.1 Definitions

Draft — The document is a draft version only. The content is still under internal review and subject to formal approval, which may result in modifications or additions. NXP Semiconductors does not give any representations or warranties as to the accuracy or completeness of information included herein and shall have no liability for the consequences of use of such information.

9.2 Disclaimers

Limited warranty and liability — Information in this document is believed to be accurate and reliable. However, NXP Semiconductors does not give any representations or warranties, expressed or implied, as to the accuracy or completeness of such information and shall have no liability for the consequences of use of such information.

In no event shall NXP Semiconductors be liable for any indirect, incidental, punitive, special or consequential damages (including - without limitation - lost profits, lost savings, business interruption, costs related to the removal or replacement of any products or rework charges) whether or not such damages are based on tort (including negligence), warranty, breach of contract or any other legal theory.

Notwithstanding any damages that customer might incur for any reason whatsoever, NXP Semiconductors' aggregate and cumulative liability towards customer for the products described herein shall be limited in accordance with the *Terms and conditions of commercial sale* of NXP Semiconductors.

Right to make changes — NXP Semiconductors reserves the right to make changes to information published in this document, including without limitation specifications and product descriptions, at any time and without notice. This document supersedes and replaces all information supplied prior to the publication hereof.

Suitability for use — NXP Semiconductors products are not designed, authorized or warranted to be suitable for use in life support, life-critical or safety-critical systems or equipment, nor in applications where failure or malfunction of an NXP Semiconductors product can reasonably be expected to result in personal injury, death or severe property or environmental damage. NXP Semiconductors accepts no liability for inclusion and/or use of NXP Semiconductors products in such equipment or applications and therefore such inclusion and/or use is at the customer's own risk.

Applications — Applications that are described herein for any of these products are for illustrative purposes only. NXP Semiconductors makes no representation or warranty that such applications will be suitable for the specified use without further testing or modification.

Customers are responsible for the design and operation of their applications and products using NXP Semiconductors products, and NXP Semiconductors accepts no liability for any assistance with applications or customer product design. It is customer's sole responsibility to determine whether the NXP Semiconductors product is suitable and fit for the customer's applications and products planned, as well as for the planned application and use of customer's third party customer(s). Customers should provide appropriate design and operating safeguards to minimize the risks associated with their applications and products.

NXP Semiconductors does not accept any liability related to any default, damage, costs or problem which is based on any weakness or default in the customer's applications or products, or the application or use by customer's third party customer(s). Customer is responsible for doing all necessary testing for the customer's applications and products using NXP Semiconductors products in order to avoid a default of the applications and the products or of the application or use by customer's third party customer(s). NXP does not accept any liability in this respect.

Export control — This document as well as the item(s) described herein may be subject to export control regulations. Export might require a prior authorization from national authorities.

9.3 Licenses

ICs with DVB-T or DVB-T2 functionality

Use of this product in any manner that complies with the DVB-T or the DVB-T2 standard may require licenses under applicable patents of the DVB-T respectively the DVB-T2 patent portfolio, which license is available from Sisvel S.p.A., Via Sestriere 100, 10060 None (TO), Italy, and under applicable patents of other parties.

9.4 Trademarks

Notice: All referenced brands, product names, service names and trademarks are the property of their respective owners.

10. Contents

1	Introduction	3
2	Circuit description	3
3	Design and Simulation	6
3.1	BLF888A impedance and simulation data	6
3.1.1	Impedance data	6
3.1.2	Simulation data	8
3.2	Bias and decoupling circuit	9
3.3	Thermal considerations	9
4	Test results	9
4.1	Large signal measurements	9
4.1.1	DVB-T	9
4.1.2	2-tone	14
4.1.3	Pulsed	14
5	Conclusion	15
6	Appendix A: PCB layout and Bill of Materials	16
7	Abbreviations	18
8	References	18
9	Legal information	19
9.1	Definitions	19
9.2	Disclaimers	19
9.3	Licenses	19
9.4	Trademarks	19
10	Contents	20

Please be aware that important notices concerning this document and the product(s) described herein, have been included in section 'Legal information'.

© NXP B.V. 2011.

All rights reserved.

For more information, please visit: <http://www.nxp.com>

For sales office addresses, please send an email to: salesaddresses@nxp.com

Date of release: 30 May 2011

Document identifier: AN11062